



6390 Philips Highway
Jacksonville, FL 32216
Phone (904) 737-7144

SPECIFICATION DATA SHEET

MODEL No. 3720-D
SPIN IN WITH MANUAL VOLUME DAMPER

Date: 10/16/09 rev.

Drawn by: M.D.C.

DIMENSIONAL DATA

SIZES AVAILABLE: 4" THROUGH 20"

COLLAR LENGTH: 6"

FABRICATION DATA

MATERIAL:
HOT DIPPED GALVANIZED STEEL SHEET
PER ASTM-A653 CS TYPE B.

GAUGES:

4" THROUGH 8" = 28 GAUGE
9" THROUGH 14" = 26 GAUGE
16" THROUGH 20" = 24 GAUGE

FEATURES

FABRICATED WITH CONTINUOUS WELD
LONGITUDINAL SEAM FOR NO AIR LEAKAGE
AT 2" W.G. STATIC PRESSURE.

SIZES 4" THROUGH 12" HAVE A REINFORCED
DAMPER AXIS WITH 1/4" REGULATOR.

SIZES 14" THROUGH 20" HAVE A 3/8" CONTINUOUS
ROD DAMPER AXIS WITH NYLON GROMMETS
INSTALLED AT SLEEVE PENETRATIONS.

OPTIONS

NO. 3720: SPIN IN.

NO. 3720-DS: SPIN IN WITH DAMPER AND
DAMPER HANDLE STANDOFF.

NO. 3720-DS W/ SCOOP: SPIN IN WITH DAMPER,
STANDOFF AND SCOOP.

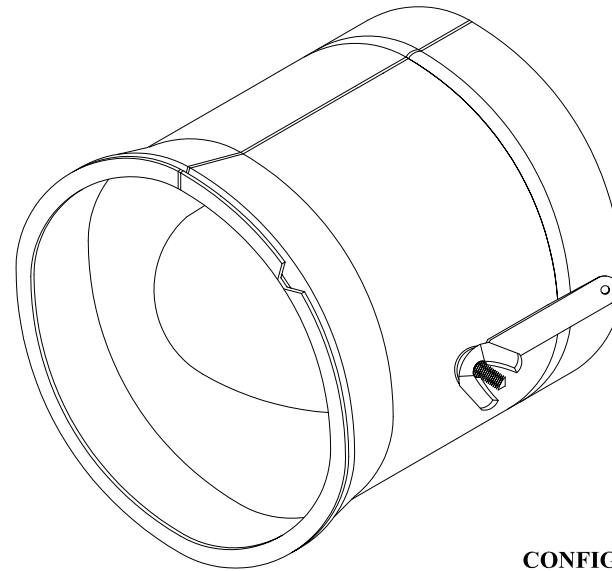

**CONFIGURATION OF
4" THROUGH 12" DIAMETERS**

SPECIAL NOTES

RECOMMENDED INSTALLATION: DAMPER AXIS PARALLEL TO AIR FLOW.

MADE TO MEET S.M.A.C.N.A. GAUGE STANDARDS. MAXIMUM 2" W.G. STATIC PRESSURE SCHEDULE.
(S.M.A.C.N.A. HVAC DUCT CONSTRUCTION STANDARDS, SECOND EDITION-1995)