



6390 Philips Highway
 Jacksonville, FL 32216
 Phone (904) 737-7144

SPECIFICATION DATA SHEET

MODEL No. 316-DSO

**TAKE OFF COLLAR FOR ROUND PIPE WITH
 THERMA SEAL GASKET FLANGE, MANUAL VOLUME
 DAMPER, DAMPER HANDLE STANDOFF AND SCOOP**

Date: 10/23/09 rev. Drawn by: DON.JR.

DIMENSIONAL DATA

DIAMETER	TO FIT PIPE SIZE
4"	8"
5"	8"
6"	10", 12", 14"
7"	10", 12", 14"
8"	10", 12"
9"	12", 14", 16"
10"	12", 14", 16"
12"	14", 16", 18"
14"	16", 18", 20"
16"	18", 20"

FABRICATION DATA

MATERIAL:
 HOT DIPPED GALVANIZED STEEL SHEET
 PER ASTM-A653 CS TYPE B.

GAUGES:
 4" THROUGH 9" = 30 GAUGE
 10" THROUGH 16" = 28 GAUGE

FEATURES

- CONTOURED FLANGE WITH THERMA SEAL GASKET DESIGNED TO MOUNT TO ROUND PIPE.
- SCOOP IS WELDED AT FLANGE TO PENETRATE INTO TRUNK DUCT.
- CRIMPED MALE CONNECTION FOR BRANCH DUCT.
- MANUAL VOLUME DAMPER INSTALLED.
- SIZES 4" THROUGH 10" HAVE DAMPER WITH 1/4" REGULATOR.
- SIZES 12" THROUGH 16" HAVE REINFORCED DAMPER AXIS WITH 1/4" REGULATOR, END BEARING WITH WASHER AND WING NUT.
- 2" DAMPER HANDLE STANDOFF.

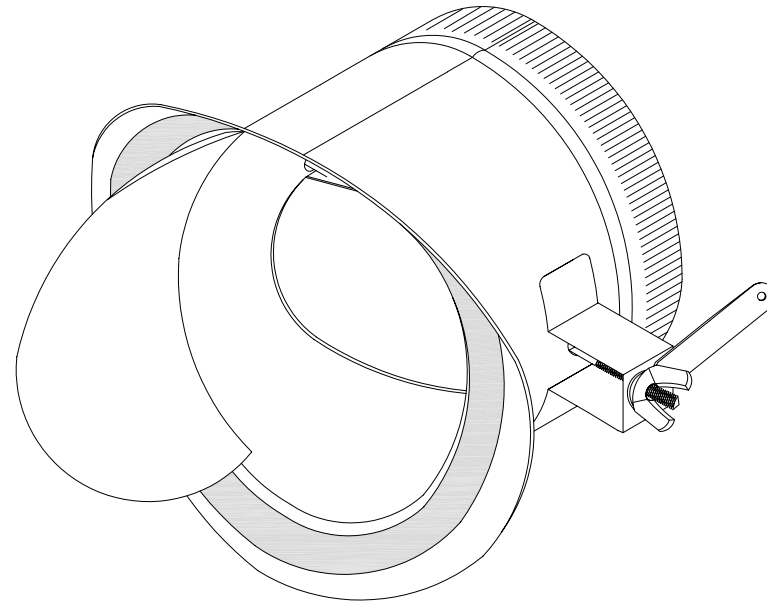

SPECIAL NOTES

- RECOMMENDED INSTALLATION: DAMPER AXIS PARALLEL TO AIR FLOW.
- THERMA SEAL GASKET ATTACHED TO OUTBOARD FLANGE BEARS FIRE HAZARD CLASS 1, FLAME SPREAD LESS THAN 25, SMOKE DENSITY LESS THAN 50.